

flexy-n



Liquid chillers Heat pumps Free Cooling

for industrial applications with scroll compressors



ErP
Tier2



❄️ | Cooling capacity from 10 to 240 kW

🔥 | Heating capacity from 11 to 195 kW

❄️ | Free cooling capacity from 10 to 240 kW

MC00000083_202602



Technology, Innovation, and Reliability in Process Cooling

Customized Process Solutions for a Sustainable Future

RPS develops customized process chillers designed to ensure continuous reliability and high performance in every industrial application. RPS's goal is to transform every thermal requirement into an **efficient and technologically advanced system**, capable of offering lasting value to its customers.

RPS looks to the future with an **innovative approach**, offering solutions that integrate **green refrigerants** such as **R290, R454B, R32, and R513A**, compliant with F-GAS and REACH regulations.

Each project is designed to meet the **highest standards of energy efficiency**, in line with Ecodesign requirements and the challenges of the energy transition.

Energy-saving technologies, full inverter systems, free cooling, and heat pumps are at the heart of the design to reduce consumption and environmental impact. Thanks to its ability to customize every detail, RPS becomes a strategic partner in the sustainable growth of its customers.

Future-Ready Technology

RPS and the Challenge of Global Warming Potential

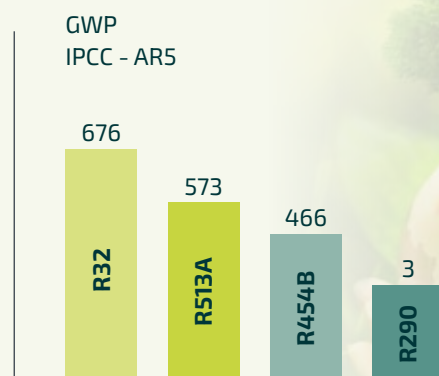

Low GWP refrigerant solutions for a more sustainable future



The RPS Group

RPS is a group with a European presence through branches in the UK, France, and Spain. Thanks to the in-house metalworking department of PIEMME S.r.l., it guarantees maximum flexibility, production speed, and customization of chillers.



RENTAL

With a large fleet of chillers ready for rental and a team of expert technicians, CHILLER SERVICE offers maintenance, repairs, and F-GAS certified support, ensuring continuity and maximum efficiency for industrial plants.

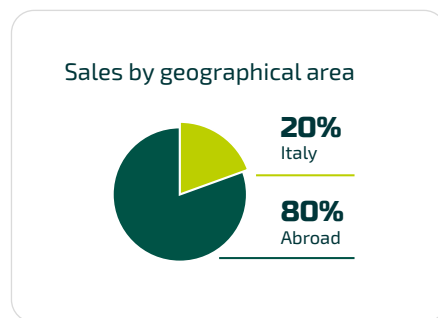

Global Quality

Over 80% of RPS production is exported thanks to a range of process chillers developed to the most rigorous European and US standards. RPS is a global partner, synonymous with efficiency, safety, and full international compliance.

Smarter, Greener, Stronger

The Next Evolution in
Process Chillers

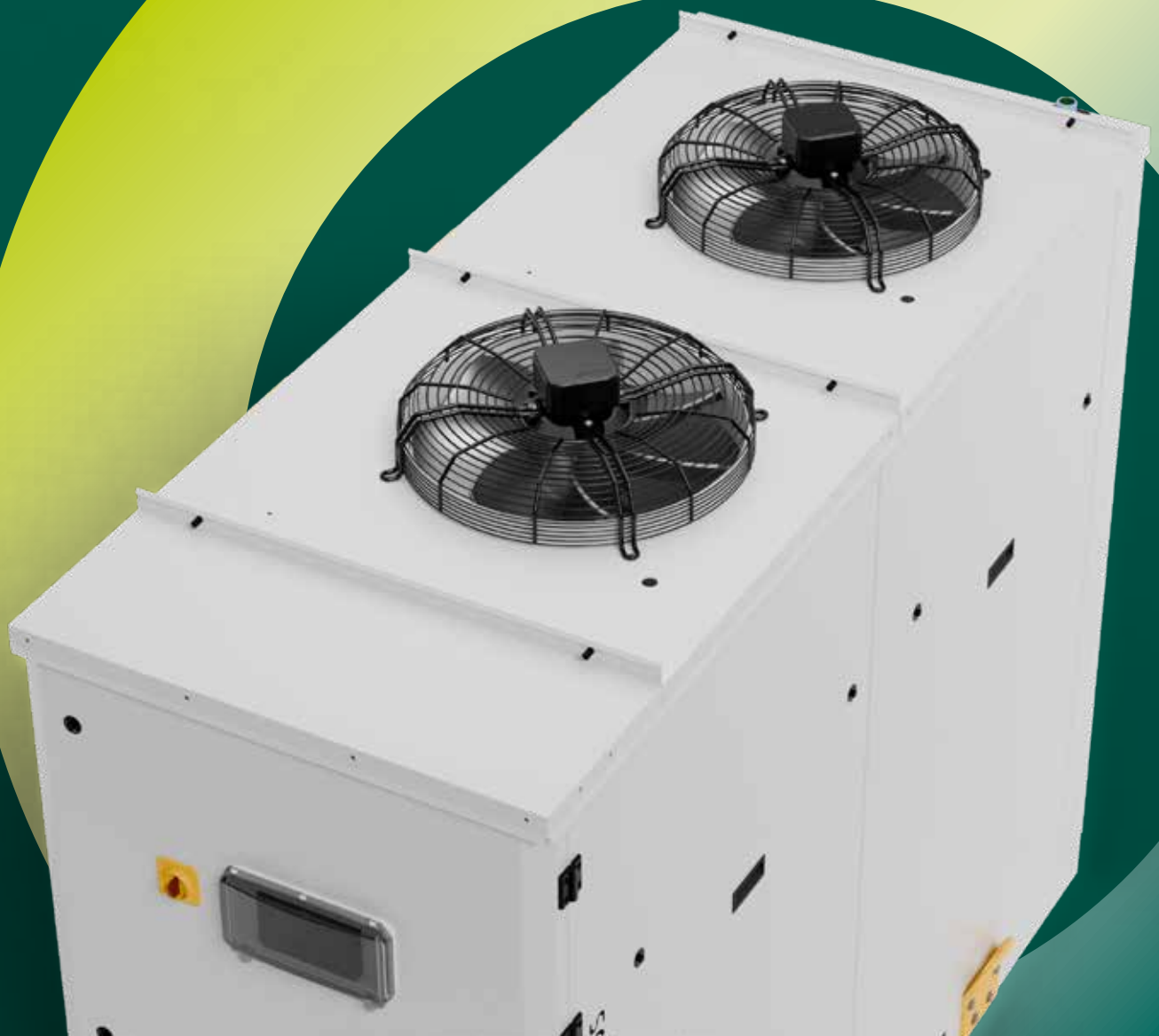

FLEXY-n

LIQUID CHILLERS – HEAT PUMPS – FREE COOLING



The FLEXY-n range offers compact, modular, and highly versatile liquid chillers, free cooling systems, and heat pumps designed to meet the specific needs of the most demanding industrial processes.

At the heart of the range is the shell and tube evaporator immersed in a buffer tank, which ensures thermal stability, low pressure drops, and maximum reliability even with fluids that are not perfectly clean.

Energy efficiency is guaranteed by the use of **latest-generation scroll compressors and low GWP refrigerants** such as R454B (R290 optional; R513A, R32 on request), while the plug & play configuration with integrated hydronic module simplifies installation and reduces start-up times.

Total reliability in all conditions

FLEXY-n chillers guarantee superior reliability thanks to **their robust architecture and extensive standard safety features**, which include an anti-freeze sensor, level sensor, compressor discharge T sensor, HP/LP pressure switches, and phase monitor. The shell & tube evaporator immersed in the buffer tank reduces compressor start-up cycles, while the automatic hydraulic bypass (optional) ensures operational continuity even in critical conditions.

Unmatched versatility

The FLEXY-n range redefines process cooling standards: **it is the only industrial chiller platform available in chiller, free cooling, and heat pump versions, with low GWP refrigerants (R454B or R32 on request). Designed to efficiently manage both water and oil**, FLEXY-n units can be installed in **atmospheric or pressurized hydraulic circuits**, ensuring maximum operational and application flexibility.

Maximum efficiency, maximum savings

With an SEPR HT of up to 6.8, FLEXY-n chillers offer **market-leading performance**, significantly reducing energy consumption and operating costs. The scroll compressors with IDV technology ensure optimal efficiency even at partial loads, while the standard EC fans guarantee quiet operation and savings. The entire range complies with ErP2021 directives and exceeds SEPR requirements, offering a rapid and tangible return on investment.

Sustainable innovation that respects the future

FLEXY-n chillers combine **advanced technology and sustainability, standing out for their "future-proof" range** which, in addition to the standard **low GWP R454B refrigerant**, is also available with **natural refrigerants such as R290 and R32 - zero PFAS (REACH compliant)**. This choice not only reduces the environmental footprint but also guarantees a safe and lasting investment compared to traditional solutions.

Modular solutions for industrial cooling

NX version Plate evaporator Non Ferrous



Designed for delicate process fluids, it uses only non-ferrous materials (stainless steel, polymers, brass). Includes AISI 316 plate evaporator, AISI 304 tank with level sensor. The hydronic module is compatible with both atmospheric and pressurized circuits. Ideal for the food, medical, and laser sectors.

FHS version Heat pump



Reversible air-water heat pumps for industrial and air conditioning applications. Compliant with the ErP Directive for seasonal efficiency (SEPR HT and SCOP). Equipped with AISI 316 plate evaporator, microprocessor protection cover, copper tube and aluminum fins coils with hydrophilic treatment, optimized for maximum heat exchange efficiency.

FB version Free Cooling



Thanks to the integrated free cooling finned coils, it is possible to exploit the outside air, which is cooler than the process water, reducing the use of compressors and energy consumption. Under favorable conditions, the system operates in total free cooling mode, with the compressors turned off, ensuring significant savings in operating costs (OPEX) and greater environmental sustainability.

Version for pressurized hydraulic circuits



In this version, the tank is designed for closed hydraulic circuits up to 6 barg and equipped with a complete automatic filling kit: pressure gauge + pressure reducer, vent valve, safety valve, expansion tank (optional), and pre-assembled fittings. A compact, safe, and ready-to-use solution.

BH version Hot gas bypass (± 0.5 K)



Equipped with an AISI 316 plate evaporator, the BH version ensures process fluid stability of ± 0.5 K thanks to hot gas regulation, brushless EC fans, and advanced PI control. Perfect for laser systems, it guarantees reliable performance even with variable thermal loads.

FO version Oil chiller



The FO version is specifically designed for oil cooling in the most demanding industrial processes. This configuration integrates a plate evaporator with an optimized exchange surface to ensure maximum thermal efficiency and high-pressure gear pumps (up to 10 bar), ensuring reliability and operational continuity even in harsh conditions.

FAL version Special High Ambient ($+55$ °C) version



The FAL (special) version is the ideal solution for high-temperature environments, up to $+55$ °C. It uses R513A refrigerant, specifically designed for high condensation temperatures, and includes insulation of the hydraulic circuit and a dedicated air conditioner for the electrical panel. Reliability and performance are guaranteed even in the most demanding conditions.

LW version Low Water Temperature (-14 °F)



The LW version is designed for the production of glycol water down to -10 °C, thanks to the increased thermal insulation of the hydraulic circuit, the flow switch, and the dedicated parameterization of the controller. Ideal for the food & beverage and wine sectors and for applications in the chemical-pharmaceutical sector where precise and reliable temperature control is required.

SL version

Low Noise



The SL version is designed to minimize noise emissions while maintaining energy efficiency. It includes acoustic insulation of the paneling, sound-absorbing hoods for compressors, and low-speed EC fans. Ideal for sensitive environments such as hotels, offices, schools, museums, and public buildings, it offers maximum acoustic comfort without compromising performance and reliability.

UL version

60 Hz



The 015-230 models are also available in a 460V/3/60Hz configuration, compliant with UL standards for the US and Canadian markets. The electrical panel, designed and certified according to UL508A, uses high-quality components and UL electrical cables. The cabinet guarantees adequate protection for outdoor installations, with IP54 – NEMA Type1 protection rating.

Advanced microprocessor controls

The RS30 and iPRO microprocessor controls are designed by RPS to ensure maximum operational continuity, cost reduction, and intuitive management, with smart features that optimize every detail of the system.

RS30 – Simplicity and Efficiency for Standard Chillers

The RS30 control is fitted to the standard FLEXY chiller version and is based on DIXELL IC205D technology. The multilingual Visograph LCD interface provides immediate and clear access to all operating parameters, probes, and loads. Thanks to alarm management with a history of up to 100 events and integrated protections (pressure, antifreeze, water flow), operation is always under control. The dynamic set point, electronic expansion valve (EEV), and unloading functions optimize consumption, while Modbus RS485 connectivity ensures total integration with supervision systems.



iPRO – Advanced Control and Energy Saving

For advanced applications, such as FHS heat pumps and FB Free Cooling systems, the iPRO unit guarantees a superior level of control and uncompromising energy efficiency. Thanks to intelligent Free Cooling, it reduces compressor intervention and drastically lowers operating costs (OPEX). The internal data logger, real-time monitoring, and auxiliary functions (pump down, defrost, heat recovery) offer predictive and reliable management. Advanced connectivity (RS485, Ethernet/ModBus TCP/IP, RS232) allows for complete remote supervision, putting system control at your fingertips.



FLEXY-n main components

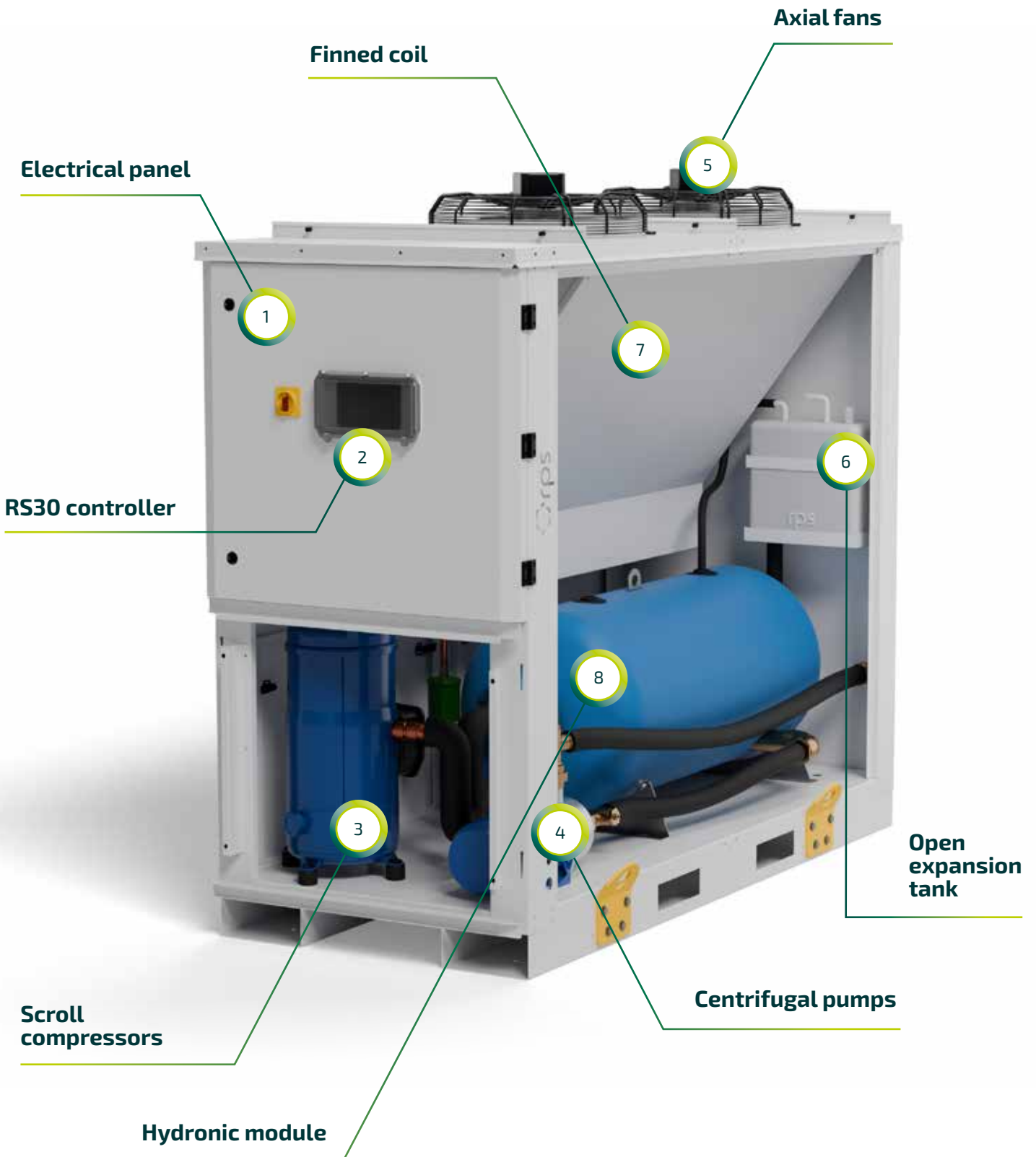

1

Electrical panel

Electrical panel compliant with EN 60204-1, IP54 (outdoor), guarantees maximum safety thanks to the interlocked main switch and electrical separation between control and power. The phase monitor protects the unit from phase failure and reversal, remote ON/OFF and general alarm contacts are available as standard.

5

EC axial fans

Brushless EC fans with inverter and 0–10V control. High-efficiency die-cast aluminum impeller. Continuous speed adjustment from 10% to 100% for maximum condensation pressure control and noise reduction.

2

RS30 controller

Advanced digital thermostat with LCD display for monitoring status, probes, and loads. Allows display and adjustment of set points, complete alarm management, and access to the service menu. Equipped with dynamic set point function and RS485 port for integration into ModBus networks.

6

Open expansion tank

Open expansion tank in HDPE plastic, with visual level indicator, mounted inside the condensing compartment and accessible from the outside. Allows the tank to be filled in a simple and controlled manner. Includes an air vent and an overflow pipe.

3

Scroll compressors

High-efficiency hermetic scroll compressors equipped with IDV technology (mod. 25-230) and mounted on anti-vibration supports. Equipped with over-temperature and over-current protection, they guarantee low noise and reduced vibrations, high resistance to liquid slugs, and maximum operational reliability.

7

Finned coil

High-efficiency finned condenser with micro-finned copper tubes and aluminum fins. Designed for high temperatures, protected by a washable aluminum air filter. Wide fin spacing for low maintenance and optimized heat exchange.

4

Centrifugal pumps

Multi-stage centrifugal pumps in AISI 304 stainless steel, ideal for process cooling. They offer high resistance, simplified maintenance, and silicon carbide/Viton seals for water/glycol. Available in P3 (3 barg) and P5 (5 barg), P3+P3, P5+P5 versions, with IE3 motors and optional INVERTER version.

8

Hydronic module – shell&tube evaporator

High-efficiency shell and tube evaporator, with copper tubes and carbon steel shell, integrated into a carbon steel hydraulic tank to ensure high flow rates and low pressure drops. Ideal for heavy industrial applications, it is protected from the risk of freezing thanks to an antifreeze probe, differential pressure switch, and level sensor. The hydronic module is compatible with both atmospheric and pressurized circuits (optional), offering maximum flexibility of use.

Main technical features

Basic version

- Environmentally friendly refrigerant: R454B (GWP=467; ODP=0), R32 (special);
- All FLEXY-n chillers comply with the limits required by ErP2021, SEPR HT (EU) 2016/2281- SEPR MT (EU) 2015/1095;
- High-efficiency hermetic scroll compressors with: IDV technology (mod.025-230) and crankcase heater;
- Shell and tube evaporator integrated into a carbon steel hydraulic tank (6 barg);
- Open expansion tank in HDPE plastic equipped with visual level indicator;
- Finned condenser with copper pipes and aluminum fins, protected by a standard washable aluminum air filter;
- HP/LP pressure switches;
- High and low pressure refrigerant gauges;
- High and low pressure transducers;
- Compressor discharge temperature sensor;
- Electronic expansion valve (EEV);
- Brushless EC axial fans complete with protective grilles and die-cast aluminum blades;
- Evaporator anti-freeze protection: differential pressure switch and anti-freeze temperature sensor;
- Pump pressure gauge 0-10 barg;
- AISI 304 stainless steel multistage centrifugal pumps: P3, P5, P3+P3, P5+P5, NP, INVERTER control;
- Electrical panel compliant with EN 60204-1, IP54 (outdoor) equipped with remote ON/OFF contacts and general alarm, phase sequence relay;
- Advanced RS30 controller with LCD display and standard RS485 ModBus port.

Optional refrigeration circuit

- [EChp] high head pressure EC fans (120Pa)
- Condensing coil protective treatments:
 - [TT] cataphoresis;
 - [FG] Finguard;
 - [EP] epoxy;
 - [BG] BLYGOLD.
- [PHR] desuperheater (spec.)
- [THR] - Total heat recovery (spec.)

Optional electrical circuit

- [A2] Stabilized 24VDC auxiliary circuit
- [PC] Multipolar electrical connector
- [SF] Soft starter
- [CP] Controller protection cover
- [VR] Voltage control relay
- [CPO] Remote ON/OFF dry contact
- [PFC] Power factor corrector
- [HT] Preheating electric resistance
- [HRA] Antifreeze system

Kit

- [AT] Anti-vibration mounts
- [RT] Wheels
- [NP] Male BSP/NPT adapters
- [WF] 100µm water filter
- [VL] Manual IN/OUT hydraulic valves
- [TR] Remote control display
- [MS] SLAVE operation (spec.)
- [MM] MASTER operation (spec.)

Hydraulic circuit option

- [AM] Manual hydraulic bypass
- [AB] Automatic hydraulic bypass
- [AP] Valve between pump and tank
- [KT] Anti-overflow kit
- [AF] Automatic filling (for open tank) / Expansion tank (for closed tank)
- [DV] Dual hydraulic circuit version with 3-way valve (independent control of 2 temperatures)
- [NX] Non-ferrous hydraulic circuit

Technical drawings

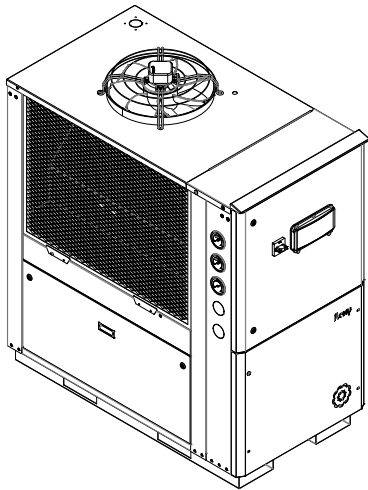

FLEXY-n1
775 x 1405 x H 1630 mm

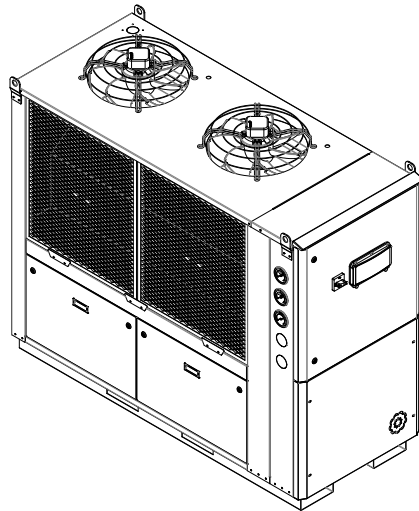

FLEXY-n2
775 x 1855 x H 1630 mm

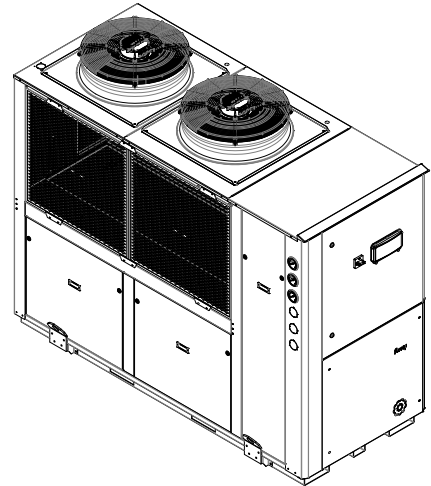

FLEXY-n3
1045 x 2455 x H 2125 mm

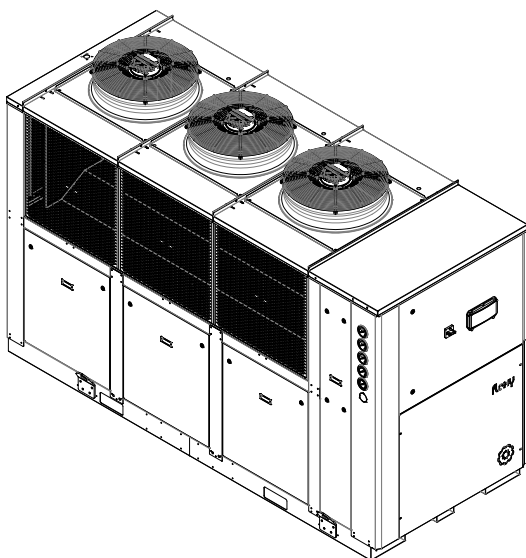

FLEXY-n4
1305 x 3220 x H 2200 mm

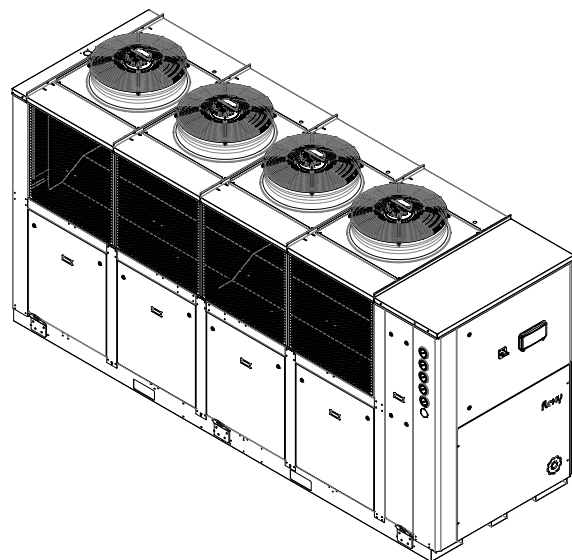

FLEXY-n5
1305 x 4060 x H 2200 mm

Technical data

FLEXY-n - R454B	Mod.	015	018	020	025	028	032	036	042	051	057	064
	Size	FLEXY-n 1			FLEXY-n 2						FLEXY-n 3	
PERFORMANCE - CHILLER												
Cooling capacity (1)	kW	9,3	12,0	15,6	20,6	23,6	26,2	30,4	34,6	37,6	49,4	54,8
Electrical power consumption (1)	kW	3,0	3,7	5,0	6,9	7,9	9,0	9,8	11,2	12,8	15,0	17,2
Nominal flow rate (1)	m ³ /h	1,6	2,06	2,69	3,53	4,1	4,5	5,2	6,0	6,5	8,5	9,4
Pressure drops (1)	kPa	4,2	6,1	9	7,9	9,6	11,2	16,7	20,2	22,8	19,9	23,2
EER - Energy Efficiency Ratio (1)	kW/kW	3,15	3,27	3,13	3,00	2,98	2,91	3,12	3,09	2,94	3,29	3,19
Cooling capacity (2)	kW	12,4	15,8	20,2	26,7	30,5	33,8	39,2	44,3	47,7	63,7	70,5
Electrical power consumption (2)	kW	2,93	3,65	4,97	6,53	7,7	8,9	9,6	11,4	13,0	14,6	17,0
EER - Energy Efficiency Ratio (2)	kW/kW	4,23	4,33	4,06	4,09	3,96	3,79	4,08	3,89	3,67	4,36	4,15
SEPR HT(3)		5,04	5,11	5,03	5,30	5,16	5,02	5,45	5,32	5,05	6,55	6,45
PERFORMANCE - HEAT PUMP												
Nominal thermal power (4)	kW	11,1	14,2	18,5	25,1	29,0	32,3	36,3	40,3	41,9	58,7	65,9
Electrical power consumption (4)	kW	3,3	4,0	5,3	7,4	8,3	9,3	10,2	11,4	13,1	16,5	18,4
Nominal flow rate (4)	m ³ /h	2,1	2,7	3,4	4,5	5,2	5,8	6,5	7,2	7,5	10,5	11,7
COP (4)	kW/kW	3,21	3,39	3,38	3,40	3,49	3,49	3,57	3,56	3,23	3,56	3,61
SCOP (5)	kW/kW	3,37	3,40	3,25	3,29	3,30	3,23	3,26	3,24	3,24	4,13	4,18
Energy class (5)		A+	A+	A+	A+	A+	A+	A+	A+	A+	A++	A++
REFRIGERATION CIRCUIT												
No. of compressors / No. of circuits	N°	1 / 1	1 / 1	1 / 1	1 / 1	1 / 1	1 / 1	1 / 1	1 / 1	1 / 1	2 / 1	2 / 1
Number of axial fans x diameter	N° / mm	1 / 450	1 / 450	1 / 450	2 / 450	2 / 450	2 / 450	2 / 450	2 / 450	2 / 450	2 / 630	2 / 630
Air flow rate	m ³ /h	6597	6193	6153	12150	12120	12090	10890	10850	10810	24490	24420
HYDRAULIC CIRCUIT												
Available pressure pump P3 (1)	bar	3,9	3,5	3,1	3,1	3,1	3,0	2,9	2,8	2,7	3,0	3,0
Tank capacity	L	90	90	90	170	170	170	170	170	170	220	220
NOISE												
Sound pressure (6)	dB(A)	46,3	46,0	46,0	47,9	49,0	49,0	49,8	49,8	51,2	51,6	51,6
Sound power (7)	dB(A)	74,3	74,0	74,0	75,9	77,0	77,0	77,8	77,8	79,2	79,6	79,6
ELECTRICAL DATA												
Power supply unit	[V/Ph/Hz]	400/3/50										
Auxiliary circuit power supply	V	24Vac										
IP protection rating		IP54										
DIMENSIONS AND WEIGHTS												
Width (8)	mm	775	775	775	775	775	775	775	775	775	1045	1045
Depth (8)	mm	1405	1405	1405	1855	1855	1855	1855	1855	1855	2455	2455
Height (8)	mm	1630	1630	1630	1630	1630	1630	1630	1630	1630	2125	2125
Weight (8)	kg	410	410	410	500	500	500	500	500	500	870	870
Hydraulic connections	Rp	1"1/2	1"1/2	1"1/2	1"1/2	1"1/2	1"1/2	1"1/2	1"1/2	1"1/2	2"	2"

Data declared in accordance with UNI EN 14511:2022. The values shown refer to units in standard configuration tested under nominal operating conditions, with shell&tube evaporator and without accessories/options.

(1) Cold exchanger water temperature on the user side - evaporator (in/out) 12°C/7°C; Air exchanger temperature on the source side 35°C.

(2) Water temperature of cold exchanger on user side - evaporator (in/out) 20°C/15°C; Air temperature of exchanger on source side 32°C.

(3) Seasonal energy efficiency of high-temperature process cooling [REGULATION (EU) No. 2016/2281]

(4) User side hot water exchanger temperature - condenser (in/out) 40°C/45°C; Source side air exchanger temperature 7°C - RH 87%

(5) Seasonal efficiency coefficient calculated in accordance with European Regulation (EU) 813/2013 for low-temperature heat pumps

(6) Sound pressure level (cold operation) measured in free field, at a distance of 10 m from the external surface of the unit, in accordance with UNI EN ISO 3744.

(7) Sound power level determined in accordance with UNI EN ISO 3744. Values are subject to a tolerance of ±2 dB.

(8) Dimensions and empty weight of the unit in STANDARD configuration with evaporator integrated in the tank, P3 pump (without options/accessories). Tolerance +/-10%.

Technical data

FLEXY-n - R454B	Mod.	072	081	096	115	128	145	150	162	180	210	230
	Size	FLEXY-n 3			FLEXY-n 4				FLEXY-n 5			
PERFORMANCE - CHILLER												
Cooling capacity (1)	kW	60,9	68,8	74,7	93,3	103,0	113,0	119,0	146,0	158,0	177,0	195,0
Electrical power consumption (1)	kW	18,9	22,0	25,0	31,8	36,7	43,2	46,7	44,9	51,3	62,5	74,0
Nominal flow rate (1)	m ³ /h	10,5	11,8	12,9	16,1	17,8	19,5	20,5	25,1	27,2	30,5	33,5
Pressure drops (1)	kPa	27,1	32,5	36,6	37,6	43,6	50,0	53,7	35,8	40,3	47,7	54,8
EER - Energy Efficiency Ratio (1)	kW/kW	3,2	3,1	3,0	2,9	2,8	2,6	2,6	3,3	3,1	2,8	2,6
Cooling capacity (2)	kW	78,1	88,0	94,5	119,0	132,0	144,0	151,0	187,0	201,0	225,0	246,0
Electrical power consumption (2)	kW	18,7	22,1	25,3	31,7	37,3	44,2	48,0	45,2	52,1	64,3	77,1
EER - Energy Efficiency Ratio (2)	kW/kW	4,18	3,98	3,74	3,75	3,54	3,26	3,15	4,14	3,86	3,50	3,19
SEPR HT(3)		6,55	6,45	6,12	6,18	5,98	5,71	5,77	6,83	6,43	6,31	5,85
PERFORMANCE - HEAT PUMP												
Nominal thermal power (4)	kW	75,5	84,4	92,9	117,0	130,0	145,0	152,0	167,0	183,0	204,0	226,0
Electrical power consumption (4)	kW	20,5	22,6	25,2	32,4	35,9	40,5	42,7	45,4	50,2	56,4	64,9
Nominal flow rate (4)	m ³ /h	13,2	14,8	16,2	20,4	22,7	25,3	26,6	29,1	31,9	33,8	37,6
COP (4)	kW/kW	3,68	3,73	3,69	3,61	3,62	3,58	3,56	3,68	3,65	3,34	3,21
SCOP (5)	kW/kW	4,20	4,23	4,20	4,02	4,08	4,03	4,09	4,11	3,67	4,23	3,97
Energy class (5)		A++	A++	A++	A++	A++	A++	A++	A++	A+	A++	A++
REFRIGERATION CIRCUIT												
No. of compressors / No. of circuits	N°	2 / 1	2 / 1	2 / 1	4 / 2	4 / 2	4 / 2	4 / 2	4 / 2	4 / 2	4 / 2	4 / 2
Number of axial fans x diameter	N° / mm	2 / 630	2 / 630	2 / 630	3 / 630	3 / 630	3 / 630	3 / 630	4 / 630	4 / 630	4 / 630	4 / 630
Air flow rate	m ³ /h	23690	23590	23520	36260	36140	36000	35920	46840	46690	46430	46190
HYDRAULIC CIRCUIT												
Available pressure pump P3 (1)	bar	2,9	2,8	2,7	3,4	3,2	3,1	3,1	3,5	3,4	3,3	3,2
Tank capacity	L	220	220	220	620	620	620	620	800	800	800	800
NOISE												
Sound pressure (6)	dB(A)	52,1	52,1	53,7	53,8	53,8	54,7	54,7	55,1	56,7	58,9	60,3
Sound power (7)	dB(A)	80,1	80,1	81,7	81,8	81,8	82,7	82,7	83,1	84,7	86,9	88,3
ELECTRICAL DATA												
Power supply unit	[V/Ph/Hz]	400/3/50										
Auxiliary circuit power supply	V	24Vac										
IP protection rating		IP54										
DIMENSIONS AND WEIGHTS												
Width (8)	mm	1045	1045	1045	1305	1305	1305	1305	1305	1305	1305	1305
Depth (8)	mm	2455	2455	2455	3220	3220	3220	3220	4060	4060	4060	4060
Height (8)	mm	2125	2125	2125	2200	2200	2200	2200	2200	2200	2200	2200
Weight (8)	kg	870	870	870	1360	1360	1360	1360	1480	1480	1480	1480
Hydraulic connections	Rp	2"	2"	2"	2"1/2	2"1/2	2"1/2	2"1/2	3"	3"	3"	3"

Data declared in accordance with UNI EN 14511:2022. The values shown refer to units in standard configuration tested under nominal operating conditions, with shell&tube evaporator and without accessories/options.

- (1) Cold exchanger water temperature on the user side - evaporator (in/out) 12°C/7°C; Air exchanger temperature on the source side 35°C.
- (2) Water temperature of cold exchanger on user side - evaporator (in/out) 20°C/15°C; Air temperature of exchanger on source side 32°C.
- (3) Seasonal energy efficiency of high-temperature process cooling [REGULATION (EU) No. 2016/2281]
- (4) User side hot water exchanger temperature - condenser (in/out) 40°C/45°C; Source side air exchanger temperature 7°C - RH 87%
- (5) Seasonal efficiency coefficient calculated in accordance with European Regulation (EU) 813/2013 for low-temperature heat pumps
- (6) Sound pressure level (cold operation) measured in free field, at a distance of 10 m from the external surface of the unit, in accordance with UNI EN ISO 3744.
- (7) Sound power level determined in accordance with UNI EN ISO 3744. Values are subject to a tolerance of ±2 dB.
- (8) Dimensions and empty weight of the unit in STANDARD configuration with evaporator integrated in the tank, P3 pump (without options/accessories). Tolerance +/-10%.

Operating limits

Cooling

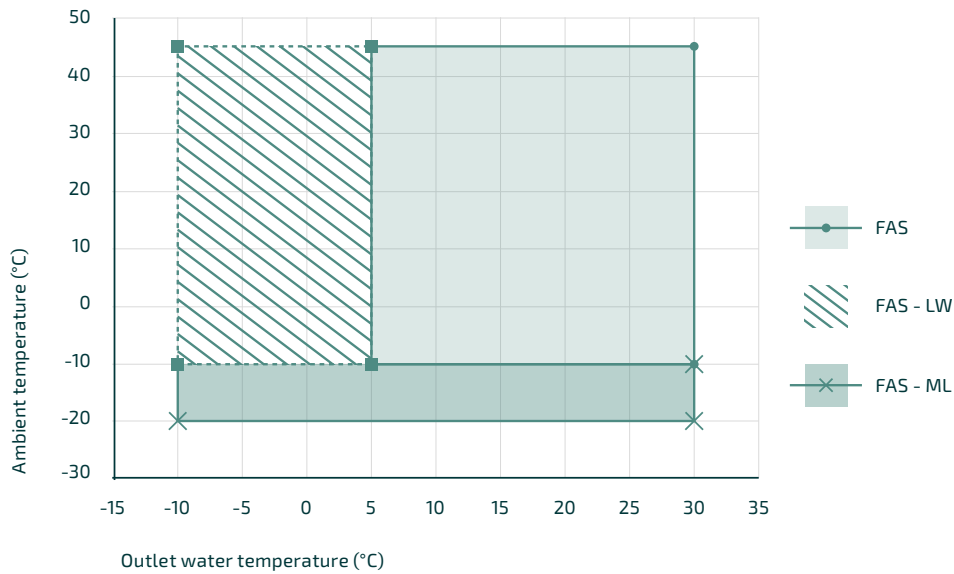

FAS liquid chillers are designed to guarantee full load operation up to an outdoor temperature of +45°C in summer and down to -10°C in winter (-20°C ML version). In the standard configuration, they produce chilled water with an evaporator outlet temperature of up to +30 °C, with a minimum limit of +5 °C, which can be reduced to -10 °C in the LW version.

Why choose FLEXY-n chillers and free cooling systems

Green & Future Proof

Low GWP R454B refrigerant and natural R290 option (R32 on request): future-proof solutions, compliant with F-GAS and REACH directives, to reduce your environmental footprint and protect your investment.



Maximum Efficiency, Maximum Savings

SEPR HT up to 6.8, IDV scroll compressors, and EC fans: top-of-the-line performance, reduced consumption, and a quick return on investment.



Connectivity & Control

Advanced control via RS30 controller, standard RS485 ModBus interface and master/slave options.



Total Reliability in All Conditions

Robust architecture, standard sensors and safety devices, submerged evaporator and automatic hydraulic bypass (optional) for operational continuity even in critical conditions.



Unmatched Versatility

The only process cooling platform available in chillers, free cooling and heat pumps; manages water and oil in atmospheric or pressurized circuits, ensuring maximum application flexibility.



Heating

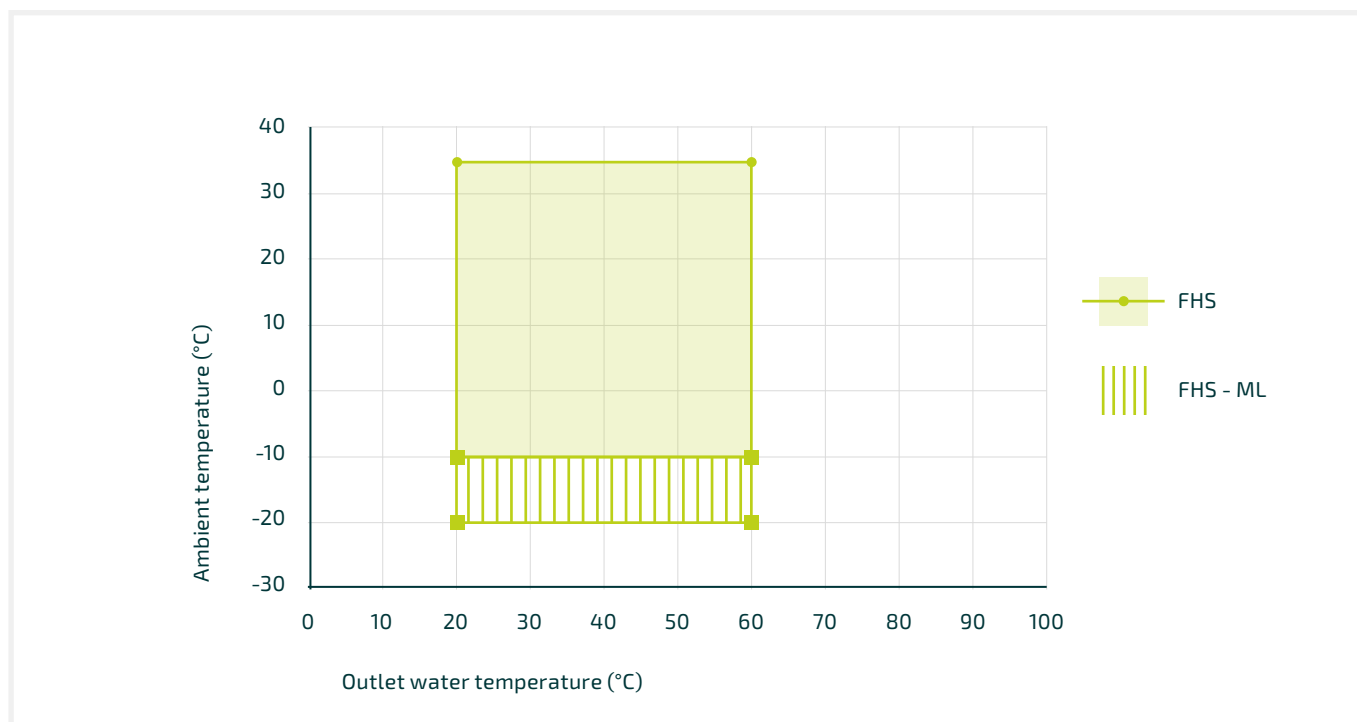

FHS heat pumps are designed to guarantee full load operation up to an outdoor temperature of +35°C in mid-seasons and down to -10°C in winter (down to -20°C in the ML version). In the standard configuration, they produce water on the user side with an evaporator outlet temperature of up to +60 °C, with a minimum limit of +20 °C.

Why choose FLEXY-n heat pumps

Sustainability and Regulatory Compliance

Low GWP refrigerants: Low GWP R454B refrigerant and natural R290 option (R32 on request). Future-proof solutions, compliant with F-GAS and REACH directives, to reduce your environmental footprint and protect your investment.



Heating efficiency

ErP2021 compliance: COP up to 3.7 and SCOP up to 4.2. Reduction in seasonal energy costs with reliable performance even at partial loads.



Extended operation

Guaranteed operation at outdoor temperatures from -20 °C (ML version) to +35 °C, for industrial applications and technical comfort.



Reliability and Safety

Integrated sensors (antifreeze, level, HP/LP pressure switches), phase monitor, and intelligent start-up cycle management to ensure operational continuity.



Application Versatility

Available in reversible configuration, can be integrated with atmospheric or pressurized hydraulic circuits, suitable for different process requirements.





RPS COOLING Srl

Via Veneto 12/B - 46029 Suzzara
(Mantova) - ITALY
Tel. +39 0376 1430010
www.rpscooling.com
sales@rpscooling.com

RPS Cooling France

3 rue Xavier Privas
01000 Bourg - en - Bresse, France
Tel. +33 06 21 60 16 02
www.rpscooling.fr
france@rpscooling.com

RPS Ingeniería de procesos, S.L.

Pol. Industrial Can Rosés
Avda. Can Rosés, 19, nave 4
08191 Rubí (Barcelona)
Tel. +34 935 66 16 29
www.rps-ing.com
info@rps-ing.com

RPS Cooling UK

2 Merus Court, Meridian
Business Park, Leicester
Leicestershire, LE19 1RJ - UK
Ph +44 77 4822 1628
rpscooling.co.uk
sales-uk@rpscooling.com